



Active drainage

below the backflow level

ACO Wastewater lifting station
and pumping stations



Lifting stations for single and multi-family houses, industry and commerce

Anyone who operates sanitary drainage appliances such as toilets, showers or a washing machine in their basement faces a problem: these rooms are usually located below the backflow level (street level). The grey and black water that accumulates cannot therefore be discharged via a gradient. Instead, it must be lifted with a wastewater lifting station so that it can flow into the sewer system. By installing a backflow loop, you also protect the basement areas against backflowing water. The ACO lifting stations made of plastic or stainless steel can overcome height differences of up to 20m, depending on the design. Depending on the usable volume, they are suitable for detached houses and apartment buildings as well as for commercial and industrial buildings. The pumps are designed for non-faecal or faecal-containing wastewater and can also be used downstream of grease separators with high volume flows.



Muli-Mini duo

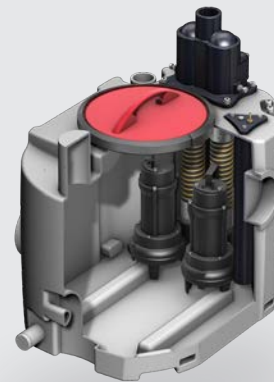

Muli-Max mono/duo



Muli-Star DDP

Muli Pro-PE XL duo



1

ACO wastewater lifting stations and pumping stations: Products for all requirements

6

2

Technical information and planning notes

9

Standards and specifications	10
Pneumatic level measurement	11
Wastewater lifting stations	12
Pump stations	13
Wastewater lifting station and pumping station versions	14
Standard requirements	15
Design of wastewater lifting stations and pumping stations	16
Application principles	17
Air bubble injection for ACO wastewater lifting stations	18
Special fastening piece for ACO wastewater lifting stations	19

3

Practical areas of application

21

Overview of wastewater lifting stations	22
Overview/configuration of pump stations	24
Single-family house	26
Multi-dwelling unit	27
Office buildings	28
Shopping centre	29
Commercial kitchen	30
Industry	31

ACO Service Lifting station

32

ACO Building Drainage and BIM data on lifting station	32
Detailed views of the BIM data for lifting stations	33
ACO 360° service – one-stop shop	34
ACO is your system provider for commissioning, maintenance and disposal	35

ACO. creating

the future of drainage

The worldwide ACO Group. A strong family you can build on.

The ACO Group is one of the global market leaders in the drainage technology sector. Climate change challenges us to come up with innovative solutions in response to new environmental influences. ACO adopts an integrated approach and focuses on professional drainage, efficient cleaning and the controlled drainage or reuse of water. The company's products comprise drainage channels and gullies, oil and grease separating systems, back flow systems and pumps as well as pressurised watertight basement and cellar windows and light shafts.

The family company, which is based in Rendsburg/Büdelndorf, was founded on the grounds of the Carlshütte, the first industrial company in Schleswig-Holstein, in 1946. The ACO Group's innovation capability is the result of intensive research and development and expertise in the processing of polymer concrete, plastic, cast iron, stainless steel and reinforced concrete.

ACO Building Drainage. Building safety - from tendering to service

We are your expert in all technical and planning matters for drainage solutions in buildings. With experience and passion, we will find the most rational and economical solution for you which meets all professional and standard requirements.

Whether for residential or industrial construction, hospitals, hotels or shopping centres: we provide tailor-made advice - both in the design and for special channels and connections to the floor sealing systems. If necessary, we will calculate the vacuum drainage and assist you in the selection and configuration of the product.

www.aco-haustechnik.de



Head Office of the ACO Group
in Rendsburg/Büdelndorf



5,000

Members of staff in more than 44 countries (Europe, North America and South America, Asia, Australia, Africa)

900 million

Euros turnover in 2019

35

Production locations in 18 countries



ACO Academy
for practical training

Owner
Hans-Julius and Iver Ahlmann (left)



ACO wastewater lifting stations and pumping stations: Products for all requirements



Rainwater, grey water and black water that accumulates below the backflow level must be fed to the public sewer system via an automatically operating lifting station or pumping station without any backflow. This basic principle applies to detached houses precisely in the same way as it does to public buildings industrial buildings.

The objective when designing a drainage system is „to guide surface water away from the building and not to draw it into the building“. Accordingly, rainfall runoff and outdoor areas must be drained via separate pumping stations outside the building.



Pumping stations are suitable for draining large outdoor areas (e.g. ramps and inner courtyards). Due to their large usable volume they are also ideally suitable for use downstream of large-volume grease separators. In commercial and industrial buildings with a large number of employees,

the selection of different pump types means that wastewater containing faecal matter can also be transported. Pumping stations are frequently used where it is structurally not possible to install freestanding wastewater lifting stations.



Supermarkets and shopping centres

You will find ACO lifting stations and pumping stations in drainage systems for supermarkets and shopping centres through to large shopping malls. The product range covers different applications; on the one hand upstream

and downstream of grease separators for catering establishments and on the other hand as variants for faecal wastewater in the sanitary installations of highly frequented shopping malls.



Kitchens and canteens

In commercial kitchens large quantities of at times very greasy wastewater is produced by the cleaning of pots, dishes and other kitchen equipment items. In order to convey the cleaned wastewater from the grease separator into the sewage system, special lifting stations are required that

can easily pump the sometimes aggressive kitchen wastewater. This mainly applies to hotels, refectories, canteens, motorway service areas and hospitals as well as restaurants in shopping centres, and kitchens where large quantities of food are grilled, fried or deep-fat fried.

2





Technical information and planning notes

Wastewater lifting stations and pumping stations

In public buildings, apartment buildings or commercial properties (commercial kitchens with installed grease separators in the basement), the use of the drainage points in the backflow area cannot usually be avoided.

Lifting stations or pumping stations must therefore always be installed if drainage objects are located below the backflow level and their use cannot be dispensed with in the event of a backflow. This also applies if there is a slope to the drains.

It is imperative to observe standard specifications and parameters when planning and designing the systems in order to ensure that they function safely and for a long time.

Standards and specifications

All ACO lifting stations are manufactured in accordance with the relevant standards. The performance data of the lifting stations listed in the product range are therefore determined on the basis of the specifications in the respective product standards. Furthermore, the wastewater lifting

stations are subject to regular inspections by the Landesgewerbeanstalt Bayern (Bavarian Trade Institute), which checks the production for compliance with the currently valid test standards.



Overview of relevant standards

DIN 1986-1010, published 05/2008

Drainage systems on private ground, specifications in relation to EN 752 and EN 12056.

EN 12056, Published 01/2001

Gravity drainage systems inside buildings.

Part 1: General design requirements

Part 2: Sanitary pipework, layout and calculation

Part 4: Wastewater lifting station – Planning and calculation

Part 5: Installation and testing, instructions for operation, maintenance and use

EN 12050, Published 05/2015

Wastewater lifting stations for buildings and land drainage

Part 1: Wastewater lifting stations for faecal-free wastewater

Part 2: Wastewater lifting stations for faecal-free wastewater

Part 3: Wastewater lifting stations for limited use

Part 4: Backflow preventer for non-faecal wastewater and wastewater containing faecal matter

DWA-M 167, published 12/2007

Separator and backflow prevention systems in property drainage: installation, operation, maintenance and inspection

Part 1: Legal and technical provisions

Part 5: Backflow safety valve and light liquid separators

Work contract

As EN 12056 with the remaining standard DIN 1986-100 covers all wastewater installations in the area up to and including the outer envelope of the building, and DIN 1986-100 also covers the area of the site up to and including the site boundary (in Europe EN 752 applies from the outer building envelope up to the connection to the sewer in the road), in case of a contract award, the work contract must define the standard to which the wastewater system is to be designed and built.

EN 12050 is the product standard for wastewater lifting stations. The application areas and construction and testing principles for the respective versions/components are defined in four parts.

Pneumatic level measurement

Wastewater is produced in the form of grey water (non-faecal wastewater from, for example, showers, washbasins or washing machines) or black water (faecal wastewater from toilets) by the drainage objects. The wastewater is fed to the collection tank of the lifting station via the inlet pipes.

After the pumping system has been switched on automatically, the wastewater is lifted above the backflow level through the discharge line. The wastewater is then discharged into the public sewer system at a gradient without any pressure.

1



Wastewater is fed to the collection tank via the inlet pipe. The pumping technology does not yet pump any wastewater, as no pressure has built up in the pitot tube.

2



The sewage level in the lifting station rises, the rising sewage causes an increase in pressure in the pitot tube and the connected control line due to air displacement. This is carried out by the control box. The pump is not yet activated. When the water level reaches a certain height (switch-on point) and with it a certain pressure in the control line, the pumping technology is activated by the control system.

3



Wastewater is pumped until the water level drops so low that the pumping technology is deactivated again due to the low pressure (switch-off point).

Wastewater lifting stations

Lifting stations are usually installed free-standing in the building or built into the floor slab of the basement. The standard requires that wastewater (or rainwater) that accumulates outside the building below the backflow level

is also discharged outside separately via a pumping station. Otherwise, in the event of a power failure or malfunction, damage to the building due to flooding is inevitable.



For non-faecal wastewater



- Multi-Mini sewage lifting station in utility room (cellar)
- Connection of washing machine and sink (grey water)

For faecal wastewater



- Multi-Star DDP wastewater lifting station in utility room (cellar)
- Connection of sinks (grey water) and toilets and/or urinals (black water)

Pump stations

Pump stations are usually installed in the ground outside of buildings. They have larger collection tanks in the form of shaft superstructures and usually contain submersible pumps. The submersible pumps are usually completely

surrounded by the wastewater to be pumped. The pump shaft is accessed via removable manhole covers. Depending on the system, the manhole covers can be used for load classes A, B or D according to DIN EN 124.



For non-faecal wastewater



- Powerlift-P prefabricated pumping station outdoors
- Connection of sinks and drainage channels (grey water)

For faecal wastewater



- Multi-Max prefabricated pumping station outdoors
- Connection of washing machine and sink (grey water) and toilets and/or urinal (black water)

Wastewater lifting station and pumping station versions

The question of whether a wastewater lifting station with one or two pumps must be installed in a building project can often not be answered with certainty by the customer. EN 12056-4 specifies that a double system must be installed if the wastewater inflow is not allowed to be interrupted.





A lifting station with two pumps guarantees the operational safety required in EN 12056-4, although normally only one pump is activated by the control system and pumps out the entire contents of the tank. After every pumping operation, the controller switches to the other pump to ensure that both pumps remain operational and have almost the same number of switching cycles or approximately the same total running time. If the same pump were always used to pump the wastewater, it could not be guaranteed that the second „dormant pump“ would even be functioning after a certain period of time.

Therefore, double lifting stations must be installed in the following cases in accordance with EN 12056-4:

- Hospitals
- Schools/Universities
- Shopping centres
- Office buildings
- Airports

Sometimes it is not immediately obvious which type of system has to be used. For example, in apartment buildings with a shared washing machine room, a double lifting station should also be installed to increase reliability and ensure smooth operation.

A similar case occurs with a rented basement flat - the use of a lifting station with only one pump would lead to the complete drainage of the residential unit no longer being possible if the pump were to malfunction. This would be an unacceptable condition for the residents.

Versions	For non-faecal wastewater	For faecal wastewater
With one pump		
With two pumps		

Example shows free-standing wastewater lifting stations

Standard requirements

If lifting stations are manufactured according to EN 12050, they must be manufactured and tested according to uniform criteria regarding fire behaviour, tightness, strength and durability. Classification of the lifting station performance is made on the basis of the lifting effect criteria.

A standardised test set-up is used to check the performance of the pump technology in terms of head and flow rate, which is then recorded in a diagram. Various standards are used to specify general requirements, construction and testing principles, information on materials and for the assessment and verification of constancy of performance:

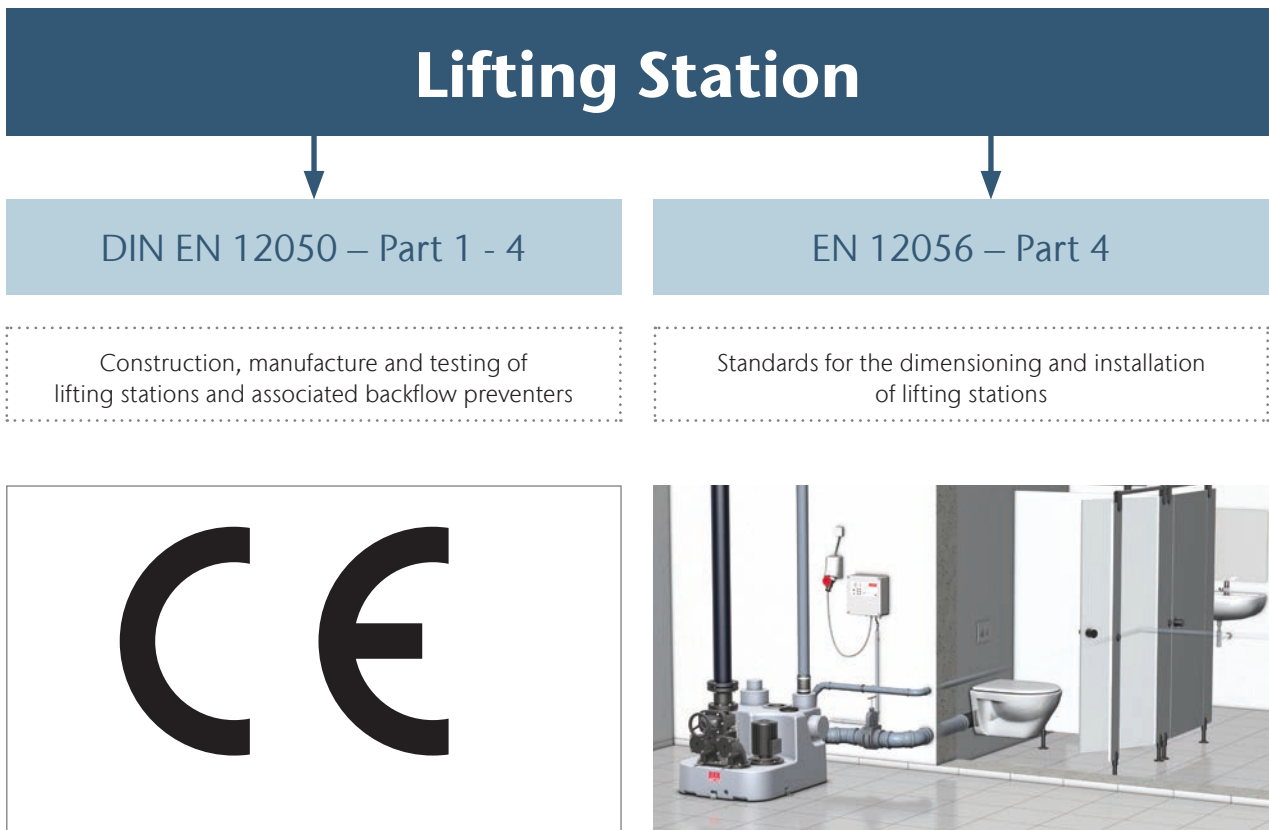

For all member countries of the European Union, the existence of a harmonised European product standard means:

- Every manufacturer/supplier of lifting stations must produce and test their products according to the specifications of EN 12050.
- The lifting stations must comply with the design specifications from EN 12050, Parts 1-4 (depending on the type of lifting station).

Manufacturers must label the lifting stations with the „CE“ mark, attach a type plate to the lifting station and provide a declaration of performance. If lifting stations are manufactured with special characteristics at the customer’s request (for example, in the case of confined installation spaces), the labelling obligation under the Construction Products Regulation does not apply.

ACO Building Drainage provides declarations of performance for all lifting stations marked with the CE symbol on the dop.aco.com website. Authorities may only require these declarations of performance for approval. The official request for the submission of further documents (such as special German approvals) is not permissible.

Design of wastewater lifting stations and pumping stations

ACO Building Drainage has developed a design programme based on the corresponding specifications from EN 12050 1 - 4. The programme can be accessed on the homepage www.aco-haustechnik.de under the heading „Design tools“.

When designing a lifting station, input values are asked for one after the other for the calculation steps below and the intermediate calculations necessary for the design are carried out automatically:

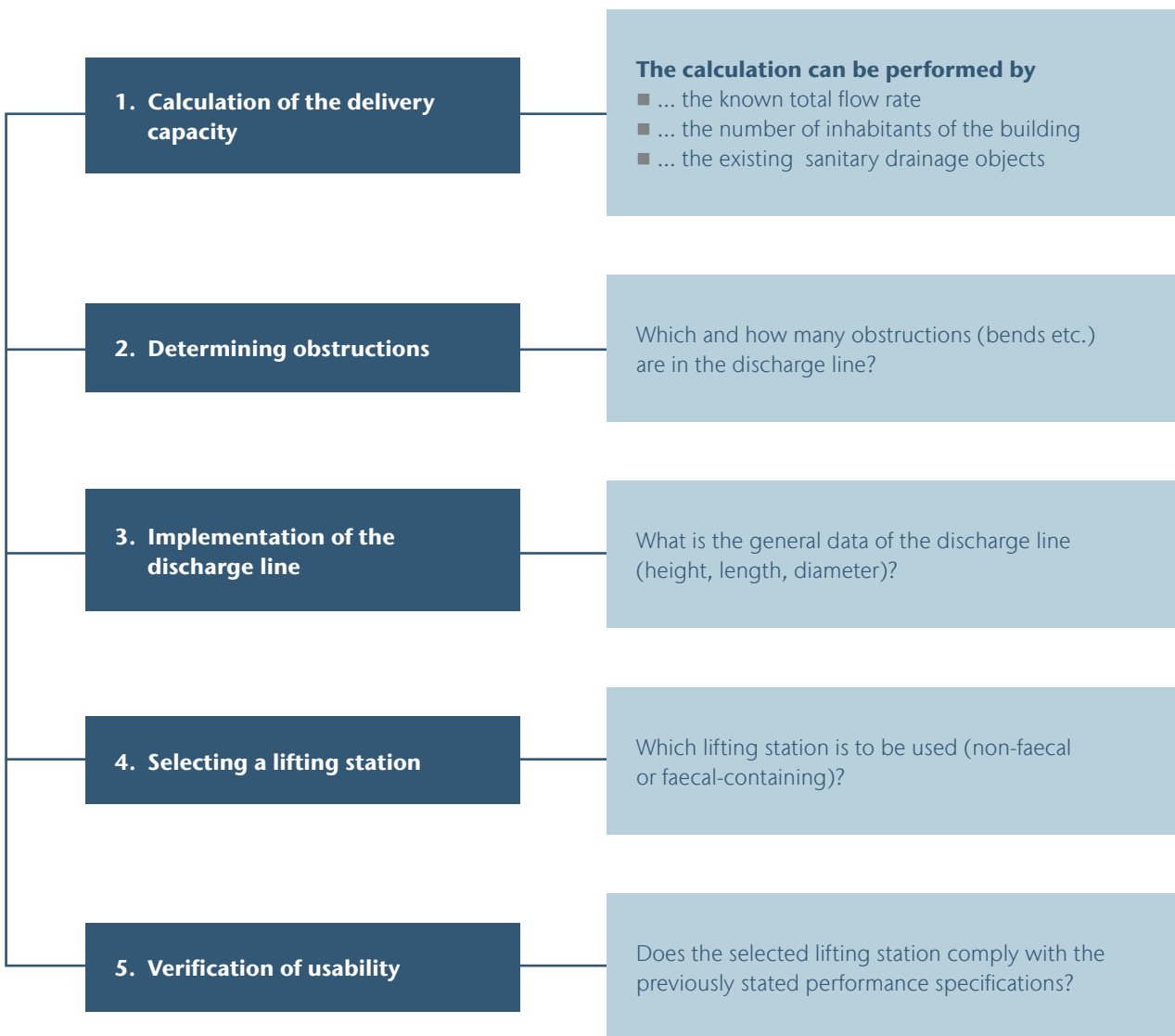
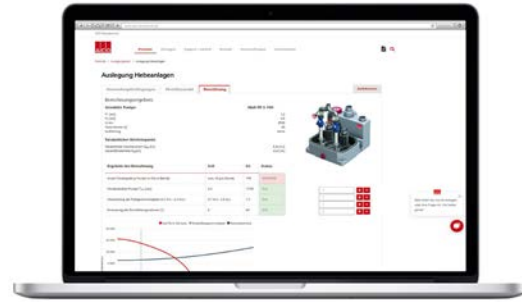

It must be ensured that all calculations are based on the specifications from the previously mentioned relevant standards or the specified empirical values. Furthermore, the calculation programme from ACO Building Drainage does not contain any specifications of its own that deviate from the standards.



Application principles



Version: Buoyancy protection

The lifting station may move during operation and in the event of flooding, even after it has been connected to various connections (inlets, discharge line, ventilation line). For this reason, the lifting station must be fixed to the installation surface by the customer so that it cannot rotate or float upwards. All free-standing lifting stations from ACO Building Drainage are supplied with suitable fixing sets.



Version: backflow loop

If the discharge line for a lifting station is installed, the following points must be observed:

- The discharge line must be kept as short as possible.
- It must be installed with as few bends as possible. Bends should be made at 45° or less.
- The installation of a backflow loop is mandatory.
- Beyond the high point of the backflow loop, the wastewater pipe can be laid without pressure at a slope to the sewer.

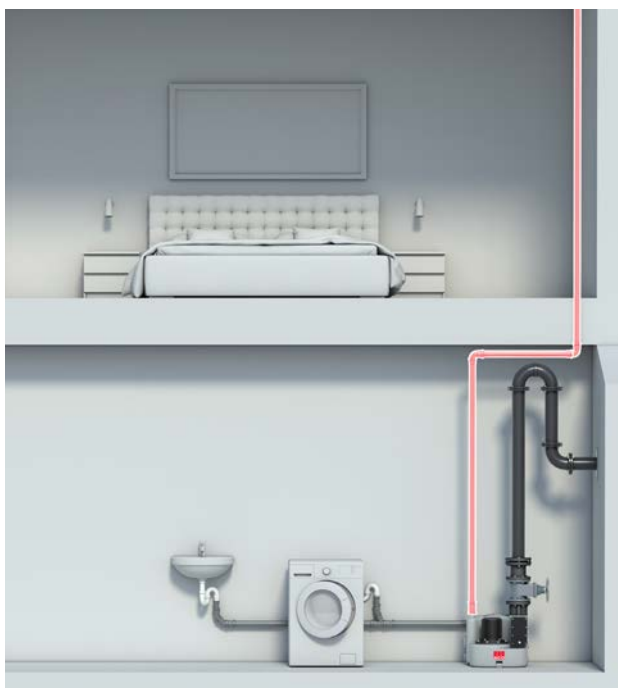

Version: Ventilation

All lifting stations must be connected to ventilation lines in accordance with DIN EN 12050-1. The ventilation lines are to be installed above the ceiling or connected to existing main or secondary vents. An exception are systems according to DIN EN 12050-2 for non-faecal water; these may also be aerated and deaerated, e.g. via activated carbon filters. Failure to vent the inlet pipe can also lead to underpressure or overpressure within the lifting station. In both cases, this can lead to the seal water, which is in the odour traps of the connected floor drains, shower channels or wash basins, either being sucked out by the negative pressure or being forced out of the drain by positive pressure. As a result, odour nuisance may occur in the drainage objects connected to the lifting station. Furthermore, it cannot be ruled out that the level measurement may be incorrect, which in turn could lead to flooding, etc.

Air bubble injection for ACO wastewater lifting stations

How does air bubble injection work with pneumatic level measurement?
Some ACO Building Drainage lifting stations are equipped with an air bubble injection for pneumatic level measurement as standard or as an optional extra.

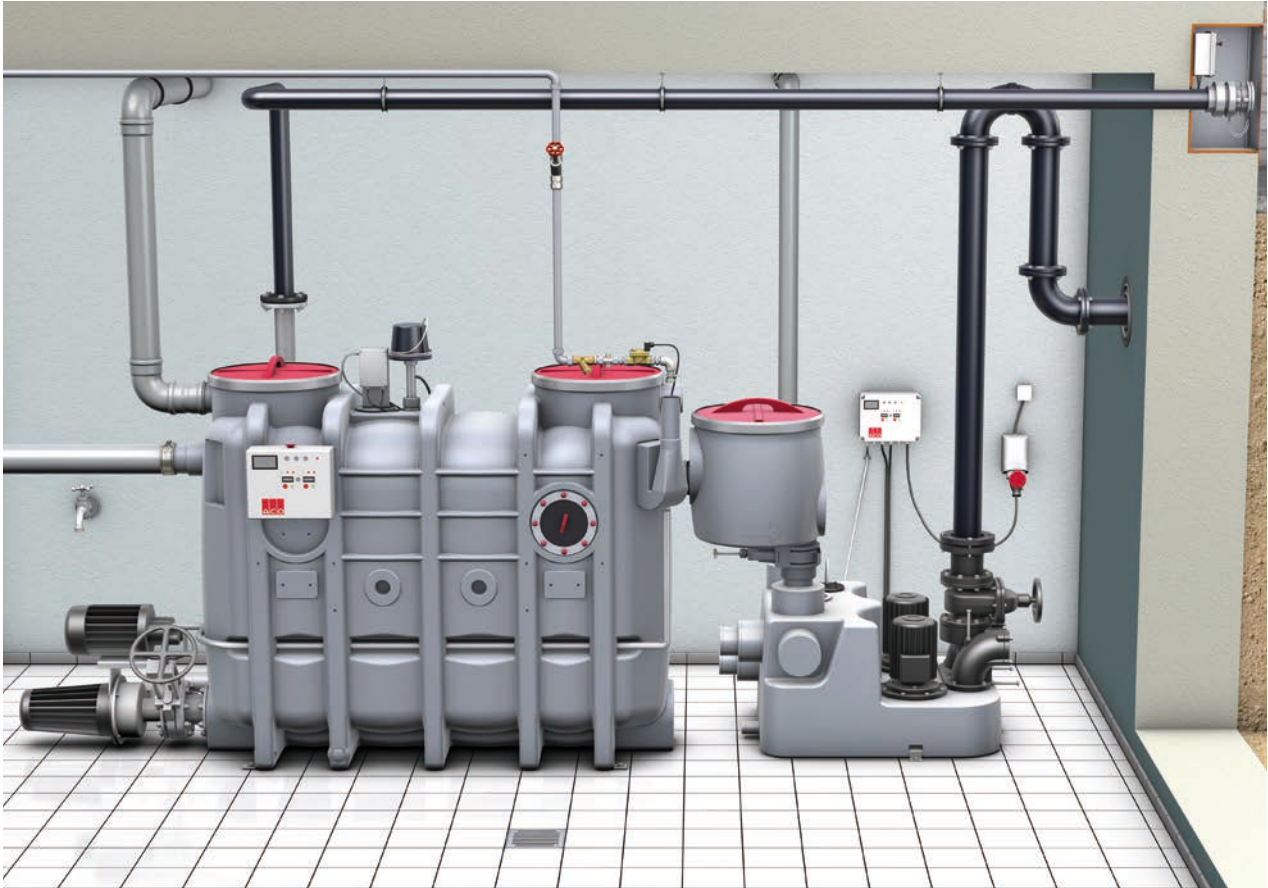

18



Lifting station downstream of a grease separator: the air bubble injection permanently bubbles air into the lifting station's pitot tube via a mini-compressor. This prevents deposits from forming in the pitot tube, which considerably improves the reliability of the level measurement. ACO Building Drainage therefore recommends equipping all lifting stations that are installed downstream of grease separators with air bubble injection or selecting a lifting station that comes with air bubble injection as standard.

Air bubble injection can also be retrofitted to most types of stations.

The special fastening piece for ACO wastewater lifting stations: flexible connection to the discharge line

In sanitary installations, pressure pipes are used that are made of different materials and therefore do not have a uniform outer diameter. This can lead to problems during the installation of the discharge line for a lifting station, as the corresponding connections of some manufacturers are not flexible and only allow the connection of a discharge line with a certain outer diameter. Furthermore, fixed connections via mechanical components cause vibrations in the discharge line, which can lead to increased noise development when the lifting station is in operation and may even damage the discharge line under certain circumstances. The remedy is the special DN 100 fastening piece from ACO Building Drainage.



The ACO special fastening piece for the flexible connection of the discharge line is included in the scope of delivery of selected lifting stations or can be purchased additionally as an optional extra. Depending on the type of lifting unit, the included or optionally available round section seal allows connections of discharge line with outside diameters of 57 - 61 mm, 73 - 76 mm, 88 - 90 mm or 108 - 114.3 mm. The pressure pipe is fixed by means of screw connections and the O-ring, which ensures flexible fastening.



The adaptation of the special fastening piece to the pressure pipe to be laid on site is simple and uncomplicated: By loosening and tightening the screw connection, the flexible seal adapts to the outer diameter of the pressure pipe. This saves time and money, as the additional assembly of a transition piece becomes unnecessary. In addition, a rubber seal reduces vibration in the discharge line. This can noticeably reduce the noise generated by the operation of the lifting station.



3

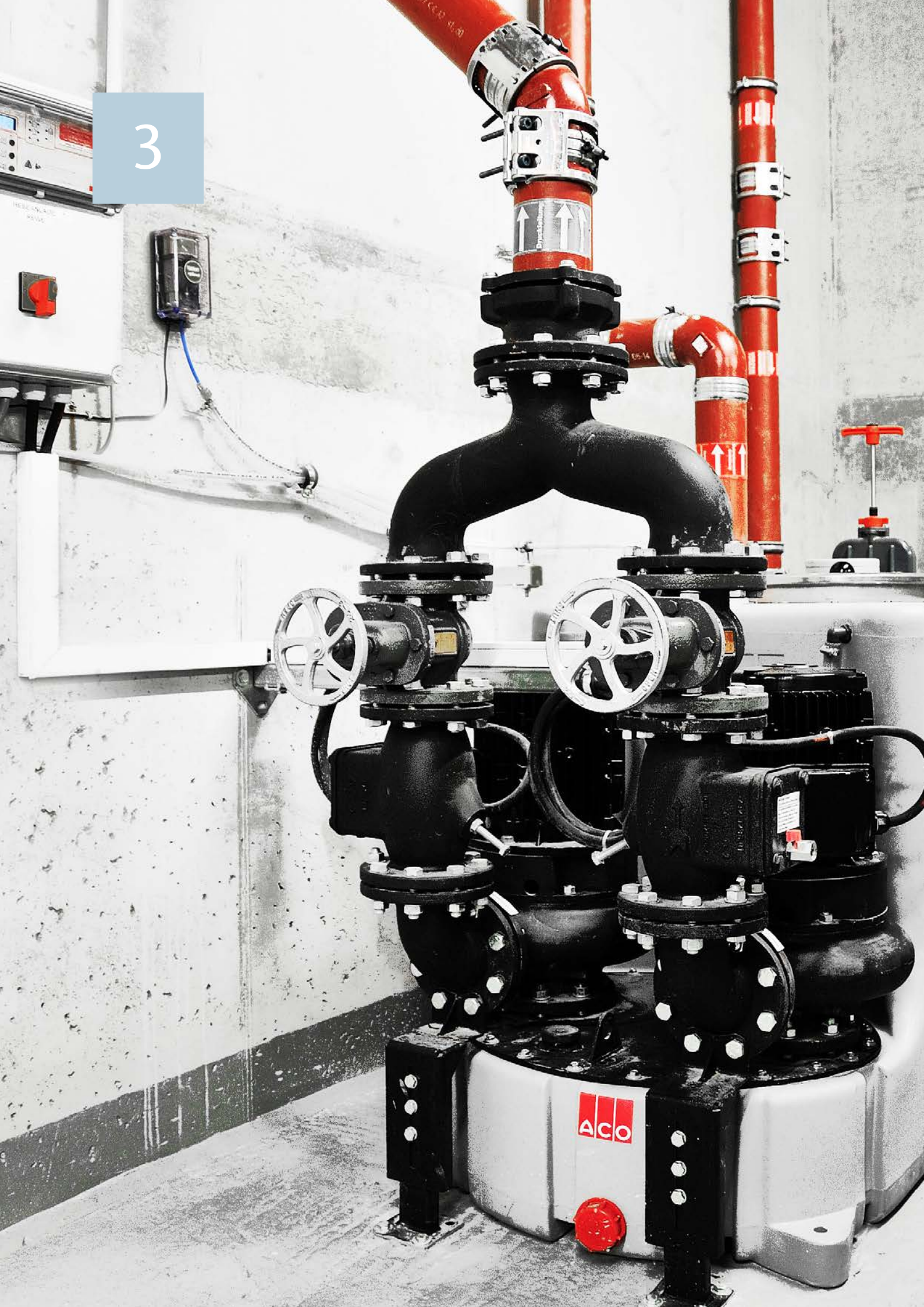

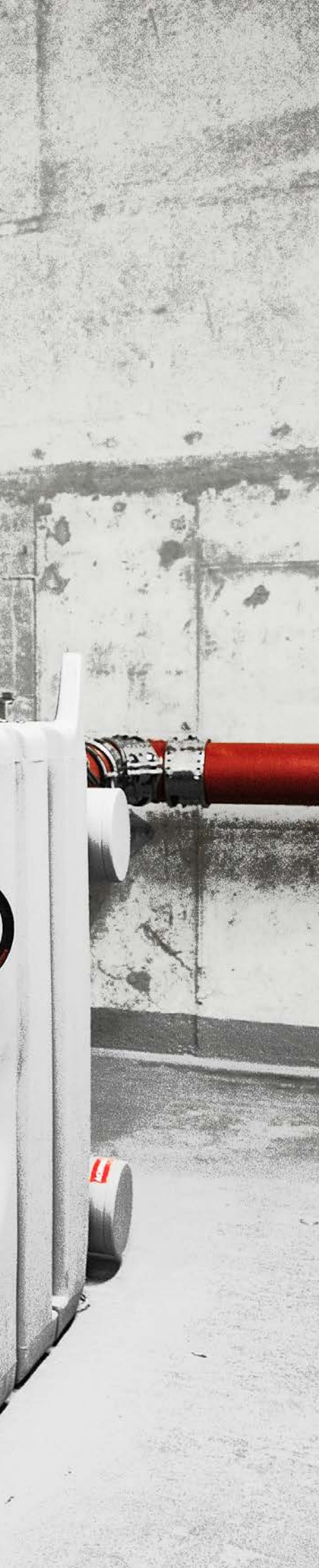

Practical

application examples

Wastewater lifting stations
and pumping stations

Wastewater lifting stations and underground pumping stations are suitable for single-family and multi-family homes as well as for commercial and industrial buildings, depending on the usable volume. The pumps are designed for non-faecal or faecal-containing wastewater and can also be used downstream of grease separators with high nominal sizes, e.g. in catering and food production. Practical application examples make it easier to select the right lifting station.

Overview of wastewater lifting stations

Waste water free of faeces

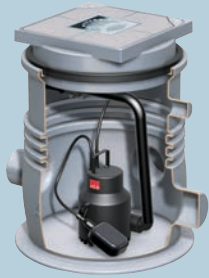

Sinkamat-K mono

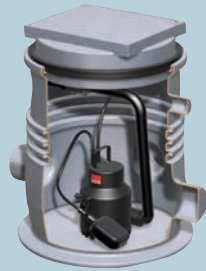

Sinkamat-K duo

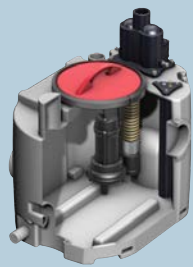

Muli-Mini mono

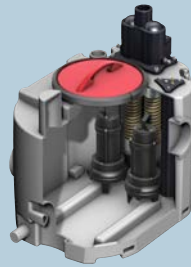

Muli-Mini duo

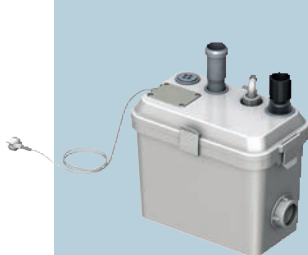

**Sinkamat-K1/K2/
KD1/KD2**



Sinkamat-Z

Special use

Upstream tank systems for low-turbulence feed of wastewater to the grease separator system

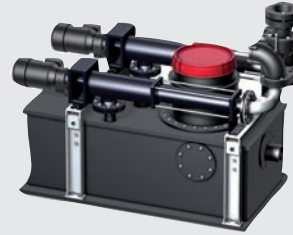

Duo upstream tank unit

The design programme for wastewater lifting stations can be found under the following link:
<https://www.aco-haustechnik.de/produkte/auslegungstools/auslegung-hebeanlagen#/>

Faecal wastewater



Muli-Star mono



Muli-Star duo



Muli-Star duo
(with increased usable volume)



Muli-PE-S mono



Muli-PE-S duo



Muli Pro-PE K duo



Muli Pro-PE K parallel
(with increased usable volume)

Configurable lifting station

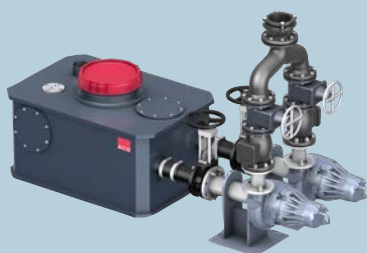

Muli Pro-PE N XL duo

Overview / Configuration of pump stations

Pump stations



Multi-Max

- Covers A 15, B 125, D 400 available
- Tested according to EN12050
- Suitable for single-family house, multi-dwelling unit, office building,
- Usable volume: 270 l



Powerlift-P

- Covers B 125, D 400 available
- Suitable for multi-dwelling units, office buildings, industry, surface drainage
- Usable volume: 550 l



Powerlift installation kit

- Available in DN 50 and DN 100
- Available in mono and duo versions suitable for on-site shafts, surface drainage, etc.
- Automatic coupling allows quick removal of the pumps without the need for tools



Pump types



SAT 50 & 75/2/32

- For non-faecal water
- DN 32
- Small submerged pump
- also available with float switch
- Operation mode: S3



SITA

- For water containing faecal matter
- DN 50
- With ATEX approval
- With cutting mechanism
- Operation mode: S1



SAT

- For non-faecal water
- DN 50
- Suitable for rainwater
- Operation mode: S1



KL-AT-M

- For water containing faecal matter
- DN 80
- With ATEX approval
- Operation mode: S1



SAT-V

- For non-faecal water
- DN 50
- Often used downstream from grease separators
- Operation mode: S1



SAT-Q

- For non-faecal wastewater
- DN 80
- Operation mode: S1

Level measurement



Backpressure bell

- Standard control for max. hose length 20 m
- Hose must be laid in an ascending direction
- Can be equipped with optional air bubble injection - for wastewater from grease separators
- Can be installed in explosion hazard areas



Pressure pick-up

- Pressure recording in the measuring head
- Signal: 4-20mA
- Cable length: 20, 40, 60, 80 m
- Cable does not have to be laid in an ascending direction
- Safety barrier must be installed when used in potentially explosive environments

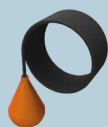

Float

- Mostly used as a redundant high level alarm for the above-mentioned measuring procedures
- Version for use in potentially explosive atmospheres available

Accessories



Outdoor column

- Outdoor installation
- Offers space for control unit and/or pressure loop, depending on the version
- Enables mounting of the above components outdoors
- Incl. heating (if a discharge line is installed)



Signal lamp/signal horn

- Each available in 12 V or 230 V versions
- Can be connected directly to the signalling system or control unit
- The horn/lamp can be triggered in intervals via the interval alarm in the MultiControl control unit



Air bubble injection

- in conjunction with dynamic pressure bell
- can be used with layer-forming media (grease)
- can be retrofitted
- increases the operational reliability of the level measurement



Signalling unit

- Error message can be forwarded via signalling system
- Integrated mains-independent alarm
- Alarm signal via horn and LED

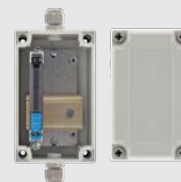

Safety barrier

- Must be used when float switches and/or pressure transducers are used in potentially explosive atmospheres

Control unit



Multi Control Control unit

- Mono and duo versions available
- Level detection possible via 4-20 mA, dynamic pressure circuit or/and float switch
- Optional: Version with Modbus RTU interface
- Pitot tube in standard version with analogue signal 4-20 mA or 0-10 V available for transmission to BMS
- Multilingual full text display
- Incl. mains-independent alarm





Single-family house

- Low delivery head ($h_{geo}^* = 3 \text{ m}$)
- Low delivery capacity ($Q = 3 \text{ l/s}$)
- Suitable for grey and black water

ACO example solution

Wastewater lifting station

Muli-Star mono



ACO System Advantages

- For domestic wastewater containing faeces
- Smooth and quiet running due to low speed
- Ready for connection
- Blockage-free free flow impeller
- Low space requirements

Accessories

- Inlet/shut-off valve
- Manual membrane pump

* h_{geo} = height difference between the water level in the wastewater lifting station and the highest point of the discharge line



Residential area

- Medium delivery head ($h_{geo}^* = 5 \text{ m}$)
- Medium delivery capacity ($Q = 7 \text{ l/s}$)
- Suitable for grey and black water

ACO example solution

Wastewater lifting station

Muli-Star duo



ACO System Advantages

- For domestic wastewater containing faeces
- Large usable volume
- Ready for connection
- High reliability
- Blockage-free free flow impeller
- High chemical resistance

Accessories

- Inlet/shut-off valve
- Manual membrane pump
- Signalling unit
- Flooding module

* h_{geo} = height difference between the water level in the wastewater lifting station and the highest point of the discharge line



Office buildings

- High delivery head ($h_{geo}^* = 8 \text{ m}$)
- High delivery capacity ($Q = 10 \text{ l/s}$)
- Suitable for grey and black water

ACO example solution

Wastewater lifting station

Muli Pro-PE K duo



ACO System Advantages

- For faecal wastewater
- Up to 330 l usable volume
- High reliability
- Very smooth running
- Robust pump technology
- Also suitable for use downstream of grease separators up to NS 20

Accessories

- Inlet/shut-off valve
- Signalling unit with GSM module
- Flooding module

* h_{geo} = height difference between the water level in the wastewater lifting station and the highest point of the discharge line



Shopping centre

- High delivery head ($h_{geo}^* = 10\text{ m}$)
- Very high delivery capacity ($Q = 20\text{ l/s}$)
- Suitable for grey and black water

ACO example solution

Wastewater lifting station

Muli Pro-PE N XL duo

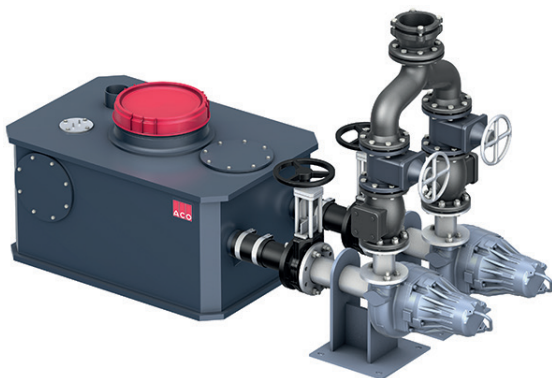

ACO System Advantages

- For faecal wastewater
- Up to 1,000 l usable volume (adaptable container dimension)
- High reliability due to adaptive impeller technology
- Very smooth running
- Robust pump technology
- Also suitable for use downstream of grease separators up to NS 30

Accessories

- Inlet/shut-off valve
- Signalling unit with GSM module
- Flooding module
- Signal horn/flashing light

* h_{geo} = height difference between the water level in the wastewater lifting station and the highest point of the discharge line



Commercial kitchen

- High delivery head ($h_{geo}^* = 8 \text{ m}$)
- High delivery capacity ($Q = 7 \text{ l/s}$)
- Suitable for grease-containing wastewater

ACO example solution

Grease separator with integrated lifting station

Lipusmart



ACO System Advantages

- For grease-containing wastewater
- High useful volume
- Only one vent stack
- Compact installation dimensions and innovative overall system control
- Integrated backflow protection
- Flexible pump technology

30

Accessories

- Inlet/shut-off valve
- Grease layer thickness measuring device
- Remote control

* h_{geo} = height difference between the water level in the wastewater lifting station and the highest point of the discharge line



Industry

- Low delivery head ($h_{geo}^* = 3 \text{ m}$)
- Very high delivery capacity ($Q = 12 \text{ l/s}$)
- Suitable for grey and black water

ACO example solution

Pump station

Powerlift-P duo Load class: D 400



Accessories

- Control unit with Modbus connection
- Outdoor cabinet for on-site discharge line and control unit
- Pressure pick-up

ACO System Advantages

- For all types of wastewater
- Very high usable volume for surface drainage
- Can be driven over by cars and lorries
- Various pump types to choose from, e.g. SAT pumps suitable for continuous operation (S1)

* h_{geo} = height difference between the water level in the wastewater lifting station and the highest point of the discharge line

ACO Building Drainage BIM data for wastewater lifting stations and pumping stations

The Revit pack for ACO lifting stations shown here as an example demonstrates a selection of wastewater lifting stations that are constantly being added to.

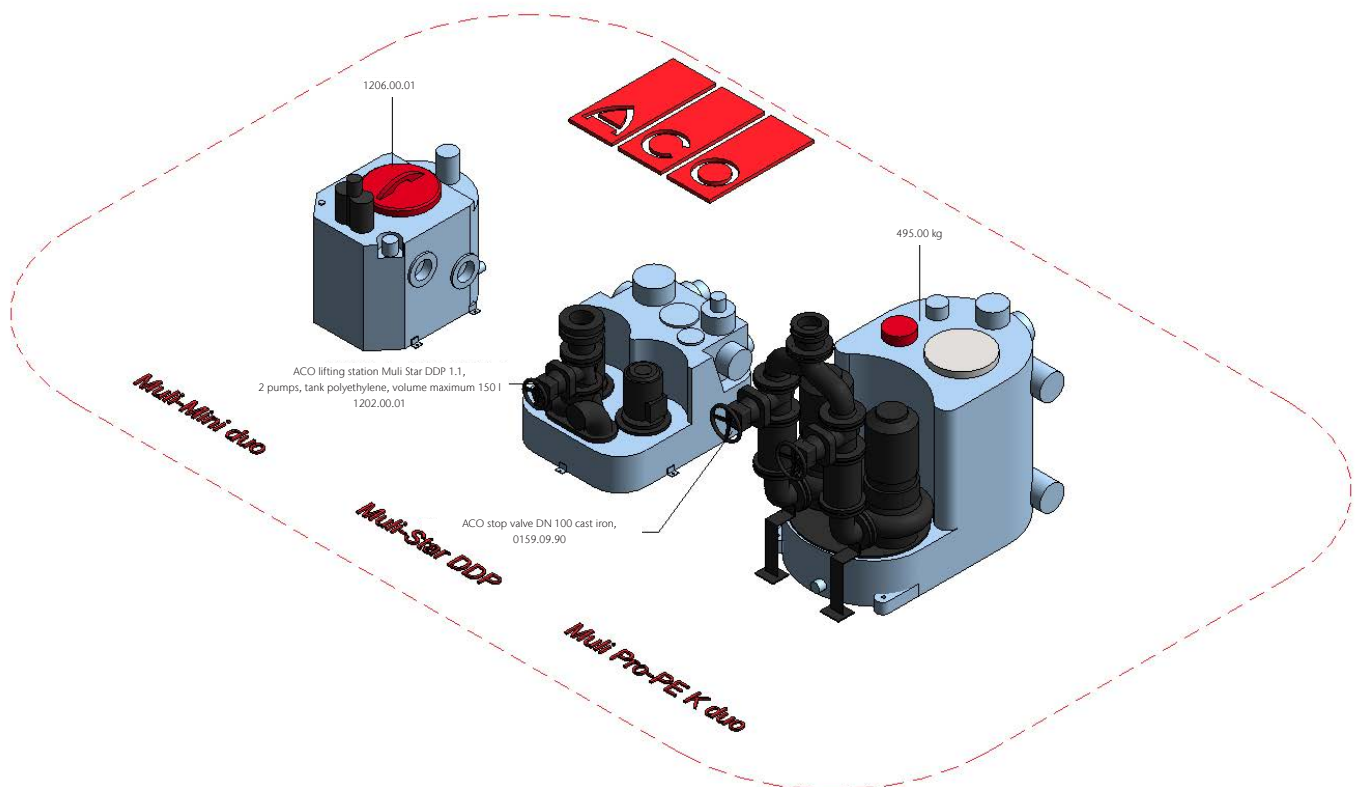

Revit Pack for ACO lifting stations and pumping stations

The Revit pack currently includes:

- ACO Multi-Mini duo
- ACO Multi-Star DDP
- ACO Multi-Pro-PE K duo
- MultiMax ACO pumping stations
- Powerlift ACO pumping stations

Including the different types of pump for the lifting station.

The pack also includes

various accessory groups:

- Electronic components (control unit, switchbox)
- Stop valve

All models are available in the Revit versions 2016/2017/2018/2019. .

Detailed views of the BIM data for lifting stations

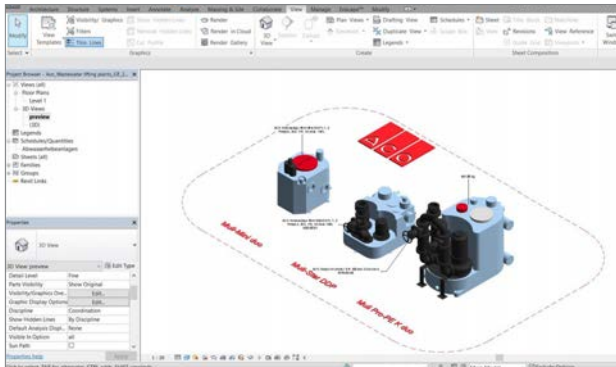

Detailed image 1

After the Revit files have been successfully loaded, the systems of the ACO Muli series are displayed in the example shown. Each record can be opened individually and inserted into the project.

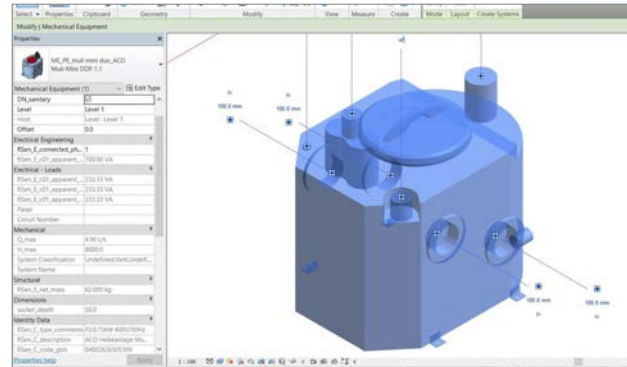

Detailed image 2

All connection points, such as inlet and outlet, are stored for each type and can be linked directly to the respective pipelines in the project. The pipe dimensions that can be connected and the function for which all nozzles/sockets are intended are displayed immediately.

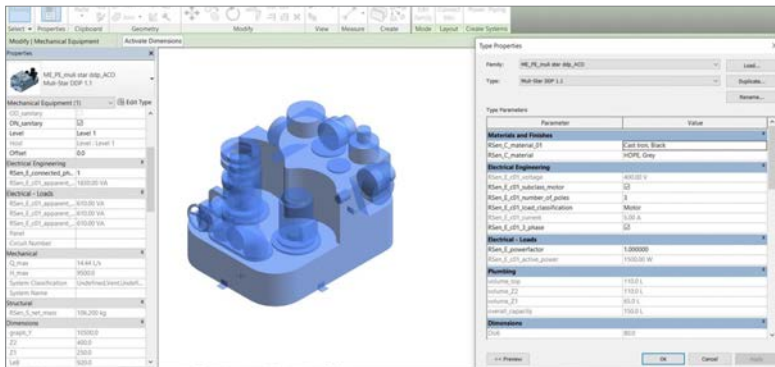

Detailed image 3

In each data set, all variants of a product are stored and for example, the motor power can be changed when the product is already installed.

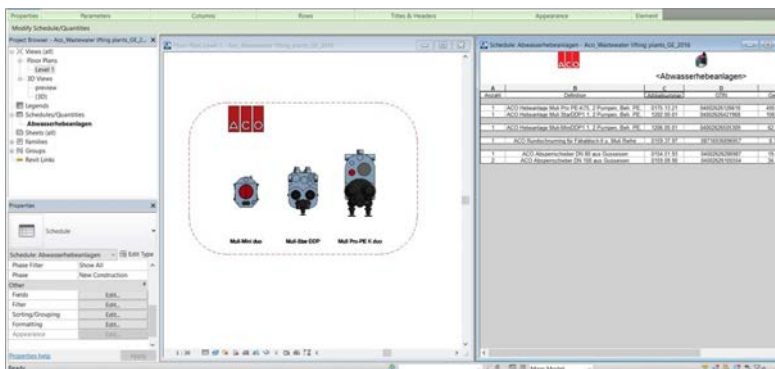

Detailed image 4

The available accessories are stored for all station types. All individual parts can be selected from the associated library and incorporated directly into the assembly.

ACO BIM - online data packs

You can conveniently download all BIM data packages from our specially set up website:

<http://bim.aco-haustechnik.de>



ACO 360° service – one-stop shop

The complete service at ACO Building Drainage offers you a comprehensive product portfolio from technical advice and sales to the conclusion of maintenance contracts. We are also there for you during commissioning right at the operator's premises.

We assist you with the procurement of spare parts and repair all „service relevant“ products. We are also your contact if you are planning structural alterations or modernisation work.



Our services

- Technical advice and sales
- Commissioning of the stations
- Maintenance according to the relevant standard
- fast repairs
- Conversions/modernisations
- Premium maintenance agreements incl. 5 year warranty and free replacement of parts
- 5-year general inspection for grease separators

The service on site is carried out by our 46 certified service partners with trained fitters, so that we can satisfy all requirements as quickly as possible and comprehensively. Together with our own fitters, we can react quickly to meet your needs. We hold regular training courses in our factory, in order to keep our service technicians and fitters up-to-date at all times. Here we reconstruct real installation situations and train directly with the product.

In conjunction with our numerous maintenance contracts, we also offer our customers a „full service“. This includes the monitoring of the stations via the internet. Generally, this service is known as „remote service“.

The high service quality of the ACO service professionals guarantees you maximum operational reliability with high cost transparency through flat-rate standard services. Long-term reliable operation of a system is only ensured with proper maintenance at regular intervals.

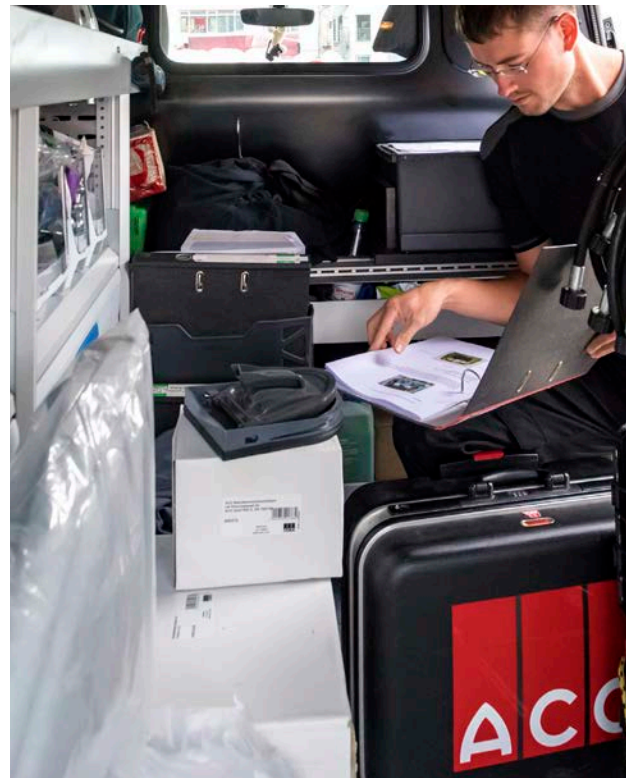

ACO is your system provider for commissioning, maintenance and disposal

From the welding of split separators on site, to the final assembly of system components, general inspection, maintenance and repair, to modernisation and system conversion - ACO provides you with everything you need from a single source. The high service quality of the ACO service professionals guarantees you maximum operational reliability with high cost transparency through flat-rate standard services. Long-term reliable operation of a system is only ensured with proper maintenance at regular intervals. The regulation is based on the respective DIN / EN standards; the list opposite shows these for the most important system groups. Grease separator systems according to DIN 4040 Part 100 as well as EN 1825-2

- Maintenance interval
 - at least once a year

Wastewater lifting stations/pumping stations in accordance with DIN 1986 Part 100 and EN 12056

- Maintenance interval:
 - Quarterly for installations in public/commercial businesses
 - twice a year for installations in multi-dwelling units
 - annually for installations in single-family houses

Maintenance agreement **Basic**

ACO Service

- General checking of condition and inspection of the station
- Checking the functionally relevant components for visible corrosion and other signs of ageing
- Documentation of the inspection results in a status report

Maintenance agreement **Comfort**

ACO Service

- all services from the Basic maintenance agreement
- Travel costs to and from
- Cleaning of the system (the organisation, implementation and remuneration of the disposal is carried out by the customer when separator systems are used)
- standard-compliant system maintenance according to individual maintenance plan
- Small materials and sealing materials up to a value of € 25.00 excl. VAT per station to be serviced
- Documentation of the results in a maintenance report

Maintenance agreement **Premium**

ACO Service

- all services from the Comfort maintenance contract
- Safety inspection and repair of the system including the supply and installation of wear parts, based on the intended use.
- Documentation of the results in a detailed status report
- Restoration of the specified condition of the station(s) with necessary repairs
 - within 48 hours (optional)

#ACOServicetips

The drainage specialist ACO Building Drainage has numerous explanatory videos showing practical tips for installation and maintenance: <https://www.service.aco/acoservicetips/>





Add here your local address

**ACO. creating
the future of drainage**

